

GATE SOLVED PAPER - CE

2001

SECTION A. (75 MARKS)

Q. 1 This question consists consists of TWENTY FIVE sub questions (1.1 - 1.25) of ONE mark each. For each of these sub-questions four possible answers (A, B, C and D) are given, out of which only one is correct.

Q. 1.1 The number of boundary conditions required to solve the differential equation

$$\frac{\partial^2 \phi}{\partial x^2} + \frac{\partial^2 \phi}{\partial y^2} = 0 \text{ is}$$

(A) 2

(B) 0

(C) 4

(D) 1

Q. 1.2 Value of the integral $I = \int_0^{\pi/4} \cos^2 x dx$ is

(A) $\frac{\pi}{8} + \frac{1}{4}$ (B) $\frac{\pi}{8} - \frac{1}{4}$ (C) $-\frac{\pi}{8} - \frac{1}{4}$ (D) $-\frac{\pi}{8} + \frac{1}{4}$

Q. 1.3 Limit of the following series as x approaches $\frac{\pi}{2}$ is $f(x) = x - \frac{x^3}{3!} + \frac{x^5}{5!} - \frac{x^7}{7!}$

(A) $\frac{2\pi}{3}$ (B) $\frac{\pi}{2}$ (C) $\frac{\pi}{3}$

(D) 1

Q. 1.4 The degree of static indeterminacy, D_s , and the degree of kinematic indeterminacy, D_k , for the plane frame shown below, assuming axial deformations to be negligible, are given by

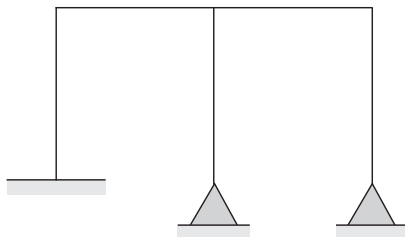
(A) $D_s = 6$ and $D_k = 11$ (B) $D_s = 6$ and $D_k = 6$ (C) $D_s = 4$ and $D_k = 6$ (D) $D_s = 4$ and $D_k = 4$

- Q. 1.5 The bending moment (in kNm units) at the mid span location X in the beam with overhangs shown below is equal to

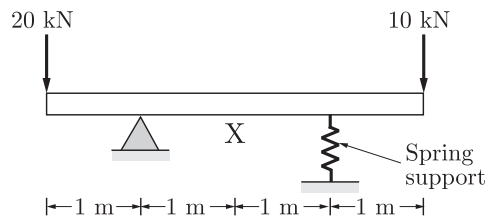

- (A) 0
(B) -10
(C) -15
(D) -20

- Q. 1.6 Identify the FALSE statement from the following, pertaining to the effects due to a temperature rise ΔT in the bar BD alone in the plane truss shown below:

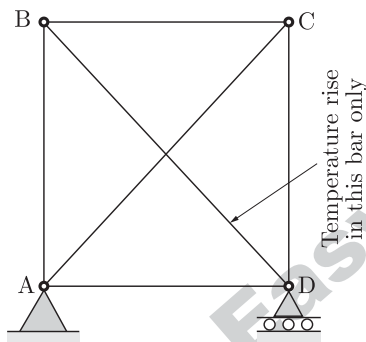

- (A) No reactions develop at supports A and D
(B) The bar BD will be subject to a tensile force
(C) The bar AC will be subject to a compressive force
(D) The bar BC will be subject to a tensile force

- Q. 1.7 Identify the correct deflection diagram corresponding to the loading in the plane frame shown below:

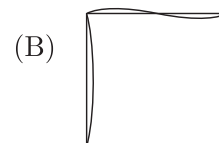
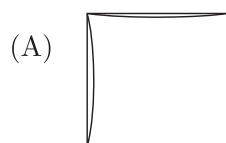
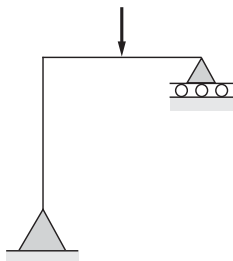

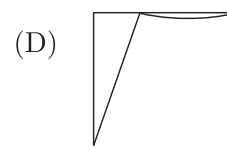
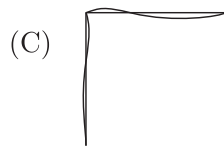

Q. 1.8 Identify the FALSE statement from the following, pertaining to the methods of structural analysis

- (A) Influence lines for stress resultants in beams can be drawn using Muller Breslau's Principle
- (B) The Moment Distribution Method is a force method of analysis, not a displacement method
- (C) The Principle of Virtual Displacements can be used to establish a condition of equilibrium
- (D) The Substitute Frame Method is not applicable to frames subject to significant sideways

Q. 1.9 Identify the FALSE statement from the following, pertaining to the design of concrete structures.

- (A) The assumption of a linear strain profile in flexure is made use of in working stress design, but not in ultimate limit state design.
- (B) Torsional reinforcement is not required to be provided at the corners of simply supported rectangular slabs, if the corners are free to lift up.
- (C) A rectangular slab, whose length exceeds twice its width, always behaves as a two way slab, regardless of the support conditions.
- (D) The 'load balancing' concept can be applied to select the appropriate tendon profile in a prestressed concrete beam subject to a given pattern of loads.

Q. 1.10 Identify the most efficient but joint (with double cover plates) shown below, each comprising 6 identical bolts with the same pitch and gauge.

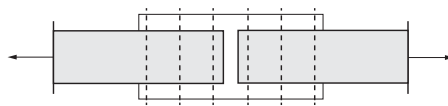

Common Elevation
(all plates have same thickness)

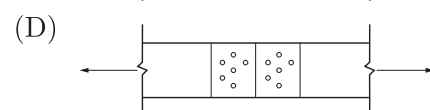
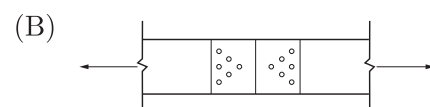
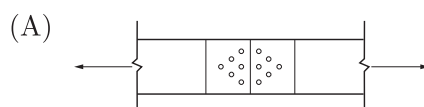

- Q. 1.11 The following two statements are made with respect to different sand samples having the same relative density. Identify if they are TRUE or FALSE.
- I. Poorly graded sands will have lower friction angle than the well graded sands.
- II. The particle size has no influence on the friction angle of sand.
- (A) II is TRUE but I is FALSE (B) Both are FALSE statements
(C) Both are TRUE statements (D) I is TRUE but II is FALSE
- Q. 1.12 The following two statements are made with reference to the calculation of net bearing capacity of a footing in pure clay soil ($\phi = 0$) using Terzaghi's bearing capacity theory. Identify if they are TRUE or FALSE.
- I. Increase in footing width will result in increase in bearing capacity.
- II. Increase in depth of foundation will result in higher bearing capacity.
- (A) Both statements are TRUE (B) Both statements are FALSE
(C) I is TRUE but II is FALSE (D) I is FALSE but II is TRUE
- Q. 1.13 The width and depth of a footing are 2 and 1.5 m respectively. The water table at the site is at a depth of 3 m below the ground level. The water table correction factor for the calculation of the bearing capacity of soil is
- (A) 0.875 (B) 1.000
(C) 0.925 (D) 0.500
- Q. 1.14 The void ratio and specific gravity of a soil are 0.65 and 2.75 respectively. The degree of saturation (in percent) corresponding to water content of 20% is
- (A) 65.3 (B) 20.9
(C) 83.7 (D) 54.4
- Q. 1.15 With respect to a $c-\phi$ soil in an infinite slope, identify if the following two statements are TRUE or FALSE
- I. The stable slope angle can be greater than ϕ
- II. The factor of safety of the slope does not depend on the height of soil in the slope.
- (A) Both statements are FALSE (B) I is TRUE but II is FALSE
(C) I is FALSE but II is TRUE (D) Both statements are TRUE
- Q. 1.16 In a Bernoulli equation, used in pipe flow, each term represents
- (A) Energy per unit weight
(B) Energy per unit mass
(C) Energy per unit volume
(D) Energy per unit flow length

- Q. 1.17 The stage-discharge relation in a river during the passage of flood is measured. If q_f is the discharge at the stage when water surface is falling and q_r is the discharge at the same stage when water surface is rising, then
- (A) $q_f = q_r$ (B) $q_f < q_r$
(C) $q_f > q_r$ (D) $q_f/q_r = \text{constant for all stages}$
- Q. 1.18 Isoleths are lines on a map through points having equal depth of
- (A) Rainfall (B) Infiltration
(C) Evapotranspiration (D) Total runoff
- Q. 1.19 A linear reservoir is one in which
- (A) Storage varies linearly with time
(B) Storage varies linearly with outflow rate
(C) Storage varies linearly with inflow rate
(D) Storage varies linearly with elevation
- Q. 1.20 Aeration of water is done to remove
- (A) Suspended Impurities (B) Colour
(C) Dissolved Salts (D) Dissolve Gases
- Q. 1.21 The following chemical is used for coagulation
- (A) Ammonium Chloride
(B) Aluminium Chloride
(C) Aluminium Sulphate
(D) Copper Sulphate
- Q. 1.22 The unit in which both sedimentation and digestion processes of sludge take place simultaneously is
- (A) Skimming Tank (B) Imhoff Tank
(C) Detritus Tank (D) Digestion Tank
- Q. 1.23 The design value of lateral friction coefficient on highway is
- (A) 1.5 (B) 0.50
(C) 0.35 (D) 0.15
- Q. 1.24 Camber on highway pavement is provided to take care of
- (A) Centrifugal Force (B) Drainage
(C) Sight Distance (D) Off-Tracking

Q. 1.25 The minimum value of CBR(%) required for granular sub-base as per Ministry of Surface Transport (MOST) specification is

- (A) 5 (B) 10
(C) 15 (D) 20

Q. 2 This question consists of Twenty Five sub-questions (2.1-2.25) of TWO marks each. For each of these sub-questions four possible answers (A, B, C and D) are given, out of which only one is correct.

Q. 2.1 Determinant of the following matrix is $\begin{vmatrix} 5 & 3 & 2 \\ 1 & 2 & 6 \\ 3 & 5 & 10 \end{vmatrix}$

(A) -76 (B) -28
(C) +28 (D) +72

Q. 2.2 The inverse Laplace Transform of $\frac{1}{(s^2 + 2s)}$ is

(A) $(1 - e^{2t})$ (B) $\frac{(1 + e^{+2t})}{2}$
(C) $\frac{(1 - e^{+2t})}{2}$ (D) $\frac{(1 - e^{-2t})}{2}$

Q. 2.3 The solution for the following differential equation with boundary conditions $y(0) = 2$ and $y'(1) = -3$ is

$$\frac{d^2y}{dx^2} = 3x - 2$$

(A) $y = \frac{x^3}{3} - \frac{x^2}{2} + 3x - 6$ (B) $y = 3x^3 - \frac{x^2}{2} - 5x + 2$
(C) $y = \frac{x^3}{2} - x^2 - \frac{5x}{2} + 2$ (D) $y = x^3 - \frac{x^2}{2} + 5x + \frac{3}{2}$

Q. 2.4 The product $[P][Q]^T$ of the following two matrices $[P]$ and $[Q]$ is

$$[P] = \begin{bmatrix} 2 & 3 \\ 4 & 5 \end{bmatrix}; [Q] = \begin{bmatrix} 4 & 8 \\ 9 & 2 \end{bmatrix}$$

(A) $\begin{bmatrix} 32 & 24 \\ 56 & 46 \end{bmatrix}$ (B) $\begin{bmatrix} 46 & 56 \\ 24 & 32 \end{bmatrix}$
(C) $\begin{bmatrix} 35 & 22 \\ 61 & 42 \end{bmatrix}$ (D) $\begin{bmatrix} 32 & 56 \\ 24 & 46 \end{bmatrix}$

Q. 2.5 The given values of the matrix $\begin{bmatrix} 5 & 3 \\ 2 & 9 \end{bmatrix}$ are

- (A) (5.13, 9.42) (B) (3.85, 2.93)
(C) (9.00, 5.00) (D) (10.16, 3.84)

- Q. 2.6 The frame below shows three beam elements OA , OB and OC , with identical length L and flexural rigidity EI , subject to an external moment M applied at the rigid joint O . The correct set of bending moments $\{M_{OA}, M_{OB}, M_{OC}\}$ that develop at O in the three beam elements OA , OB and OC respectively,

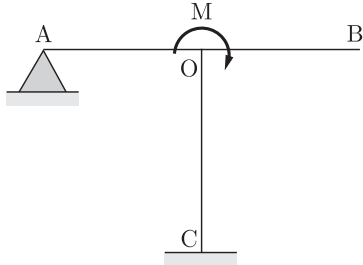

- (A) $\{3M/8, M/8, 4M/8\}$
 (B) $\{3M/11, 4M/11, 4M/11\}$
 (C) $\{M/3, M/3, M/3\}$
 (D) $\{3M/7, 0, 4M/7\}$

- Q. 2.7 Identify, from the following, the correct value of the bending moment M_A (in kNm units) at the fixed end A in the statically determinate beam shown below (with internal hinges at B and D), when a uniformly distributed load of 10 kN/m is placed on all spans. (Hint: Sketching the influence line for M_A or applying the Principle of Virtual Displacements makes the solution easy).

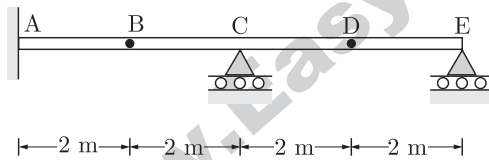

- (A) -80 (B) -40
 (C) 0 (D) $+40$

- Q. 2.8 The end moment (in kNm) units) developed in the roof level beams in the laterally loaded frame shown below (with all columns having identical cross-sections) according to the Cantilever Method of simplified analysis, is

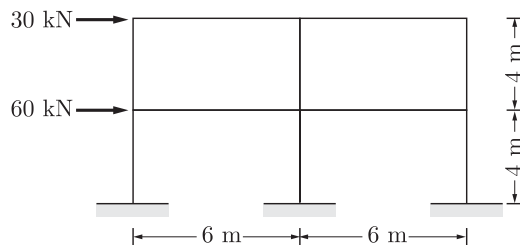

- (A) 7.5 (B) 15
 (C) 20 (D) 30

Q. 2.9 Consider the following two statements related to reinforced concrete design, and identify whether they are TRUE or FALSE:

- I. Curtailment of bars in the flexural tension zone in beams reduces the shear strength at the cut-off locations.
- II. When a rectangular column section is subject to biaxially eccentric compression, the neutral axis will be parallel to the resultant axis of bending.

- (A) Both statements I and II are TRUE
- (B) Statement I is TRUE, and statement II is FALSE
- (C) Statement I is FALSE, and statement II is TRUE
- (D) Both Statements I and II are FALSE

Q. 2.10 Consider the following two statements related to structural steel design, and identify whether they are TRUE or FALSE:

- I. The Euler buckling load of a slender steel column depends on the yield strength of steel.
- II. In the design of laced column, the maximum spacing of the lacing does not depend on the slenderness of column as a whole.

- (A) Both statements I and II are TRUE.
- (B) Statement I is TRUE, and Statement II is FALSE
- (C) Statement I is FALSE, and statement II is TRUE
- (D) Both Statements I and II are FALSE

Q. 2.11 Identify the two FALSE statements from the following four statements.

- I. The consolidation of soil happens due to the change in total stress.
- II. When Standard Penetration Tests are performed in fine sands below the water table, the dilation correction is applied after the overburden correction is applied.
- III. Over consolidated clays will have predominantly cohesive strength as compared to the frictional strength.
- IV. Compaction of soils is due to expulsion of water.

- (A) II & III
- (B) I & IV
- (C) I & III
- (D) II & IV

Q. 2.12 The critical slip circle for a slope is shown below along with the soil properties.

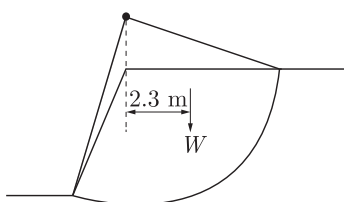

- The length of the arc of the slip circle is 15.6 m and the area of soil within the slip circle is 82 m^2 . The radius of the slip circles is 10.3 m. The factor of safety against the slip circle failure is nearly equal to
- (A) 1.05 (B) 1.22
(C) 0.78 (D) 1.28
- Q. 2.13 The coefficients of permeability of a soil in horizontal and vertical directions are 3.46 and 1.5 m/day respectively. The base length of a concrete dam resting in this soil is 100 m. When the flow net is developed for this soil with 1 : 25 scale factor in the vertical direction, the reduced base length of the dam will be
- (A) 2.63 m (B) 4.00 m
(C) 6.08 m (D) 5.43 m
- Q. 2.14 A plate load test was conducted in sand on a 300 mm diameter plate. If the plate settlement was 5 mm at a pressure of 100 kPa, the settlement (in mm) of a $5 \text{ m} \times 8 \text{ m}$ rectangular footing at the same pressure will be
- (A) 9.4 (B) 18.6
(C) 12.7 (D) 17.8
- Q. 2.15 Identify the two TRUE statements from the following four statements.
- I. Negative skin friction is higher on floating piles than on end bearing piles.
II. All other things being the same in footings on sand, the footing with smaller width will have lower settlement at the same net pressure.
III. The void ratio of soils is always less than 1.0.
IV. For determining the depth of embedment of anchored sheet piles, net moment at the anchor elevation is set to zero.
- (A) I & IV (B) I & III
(C) II & IV (D) II & III
- Q. 2.16 A 15 cm length of steel rod with relative density of 7.4 is submerged in a two layer fluid. The bottom layer is mercury and the top layer is water. The height of top surface of the rod above the liquid interface in 'cm' is
- (A) 8.24 (B) 7.82
(C) 7.64 (D) 7.38
- Q. 2.17 The direct runoff hydrograph of a storm obtained from a catchment is triangular in shape and has a base period of 80 hours. The peak flow rate is $30 \text{ m}^3/\text{sec}$ and catchment area is 86.4 km^2 . The rainfall excess that has resulted the above hydrograph is
- (A) 5 cm (B) 8 cm
(C) 10 cm (D) 16 cm

- Q. 2.18 A field was supplied water from an irrigation tank at a rate of 120 lit/sec to irrigate an area of 2.5 hectares. The duration of irrigation is 8 hours. It was found that the actual delivery at the field, which is about 4 km from the tank, was 100 lit/sec. The runoff loss in the field was estimated as 800 m^3 . The application efficiency in this situation is
- (A) 62% (B) 72%
(C) 76% (D) 80%
- Q. 2.19 A trapezoidal channel with bottom width of 3 m and side slope of IV : 5H carries a discharge of $8.0 \text{ m}^3/\text{sec}$ with the flow depth of 1.5 m. The Froude number of the flow is
- (A) 0.066 (B) 0.132
(C) 0.265 (D) 0.528
- Q. 2.20 In a 1/50 model of a spillway, the discharge was measured to be $0.3 \text{ m}^3/\text{sec}$. The corresponding prototype discharge in m^3/sec is
- (A) 2.0 (B) 15.0
(C) 106.0 (D) 5303.0
- Q. 2.21 If the $\text{BOD}_{5,20}$ of waste is 150 mg/L and the reaction rate constant (to the base 'e') at 20°C is 0.35/day, the ultimate BOD in mg/L is
- (A) 97.5 (B) 181.5
(C) 212.9 (D) 230.5
- Q. 2.22 The Ca^{2+} concentration and Mg^{2+} concentration of a water sample are 160 mg/lit and 40 mg/lit as their ions respectively. The total hardness of this water sample in terms of CaCO_3 in mg/lit is approximately equal to
- (A) 120 (B) 200
(C) 267 (D) 567
- Q. 2.23 A town has an existing horizontal flow sedimentation tank with an overflow rate of $17 \text{ m}^3/\text{day}/\text{m}^2$, and it is desirable to remove particles that have settling velocity of 0.1 mm/sec. Assuming the tank is an ideal sedimentation tank, the percentage of particles removal is approximately equal to
- (A) 30% (B) 50%
(C) 70% (D) 90%
- Q. 2.24 A valley curve has a descending gradient of 1 in 40 followed by an ascending gradient of 1 in 50. The length of the valley curve required for a design speed of 80 km/hour for comfort condition is
- (A) 199 m (B) 116 m
(C) 58 m (D) 37 m

- Q. 2.25 The radius of relative stiffness for a 20 cm thick slab with $E = 3 \times 10^5 \text{ kg/cm}^2$ and poisson's ratio = 0.15, resting on a subgrade having modulus of 5 kg/cm^3 is
- (A) 10 cm (B) 80 cm
(C) 120 cm (D) 320 cm

SECTION B. (75 MARKS)

This section consists of TWENTY question of FIVE marks each. Any FIFTEEN out of these questions have to be answered. ($15 \times 5 = 75$)

- Q. 3 A car having a mass m is travelling at a constant velocity of v_0 . At time $t = 0$, the engine is shut off. assuming that the resistance to the motion of the car is proportional to the square of the instantaneous velocity (v), find v as a function of the distance travelled (x) after the engine is shutt off by setting up the differential equation using the Newton's principle.
- Q. 4 Determine the volume of the largest rectangular parallelepiped which can be inscribed in a hemisphere of radius a shown below using the maxima principle of calculus.

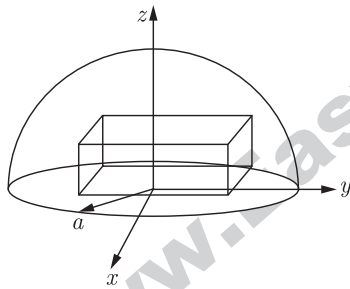

- Q. 5 The figure below shows a cable-supported cantilever beam of span L subject to a concentrated load P at mid-span.
- (a) Express the bending moment $M(x)$ at any section of the beam AB located at a distance x from the fixed end A , in terms of P , L and the cable tension T . (1)
- (b) Applying the Theorem of Least Work, derive an expression for T in terms of P , assuming $EA = \frac{\sqrt{3}EI}{L^2}$. Consider only the flexural strain energy in the beam and the axial strain energy in the cable. (4)

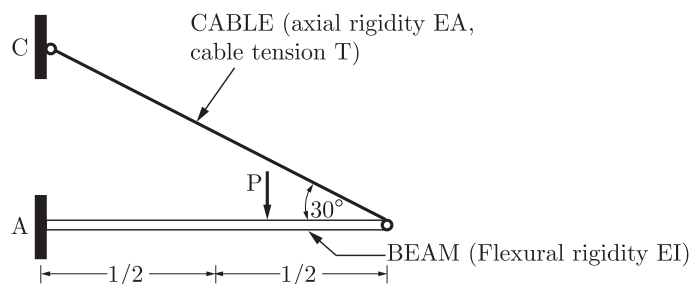

- Q. 6 The two-span continuous beam shown below is subject to a clockwise rotational slip $\theta_A = 0.004$ radian at the fixed end A . Applying the slope-deflection method of analysis, determine the slope θ_B at B . Given that the flexural rigidity $EI = 25000 \text{ kNm}^2$ and span $L = 5 \text{ m}$, determine the end moments (in kNm unit) in the two spans, the draw the bending moment diagram.

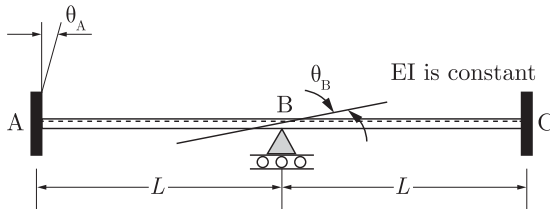

- Q. 7 The plan of a reinforced concrete column section, and the distribution of strains at the ultimate limit state are shown below. The concrete is of M20 grade and the steel of Fe 250 grade. Also sketched below, for convenience, are the concrete compression stress block and the design stress-strain curve for Fe 250, with all notations as per IS 456. Ignore the reduction in concrete area due to the embedded steel.

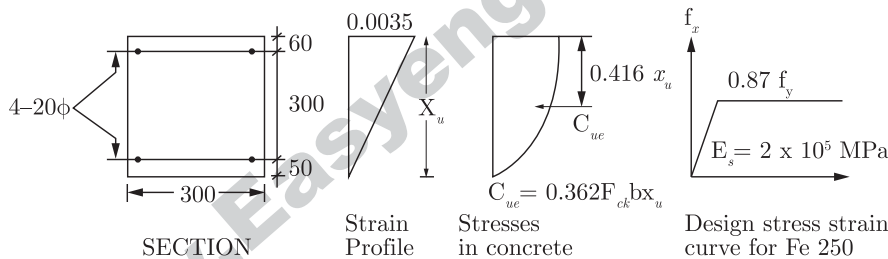

- (a) Determine the ultimate axial compression capacity P_u (in kN units). (3)
 (b) Determine the corresponding eccentricity e (in mm units) of loading, with respect to the centroidal axis at the ultimate limit state. (2)
- Q. 8 The effective spans for a simple one-way slab system, with an overhang, are indicated in the figure below. The specified ultimate design loads on the slab are 6.0 kN/m^2 and 4.5 kN/m^2 for dead loads and live loads respectively considering the possibility of live loads not occurring simultaneously on both spans, determine the maximum spacing (in mm units) of 8 mm diameter bars required as bottom reinforcement in the span AB, assuming an effective depth of 125 mm. Assume M20 concrete and Fe 415 steel.

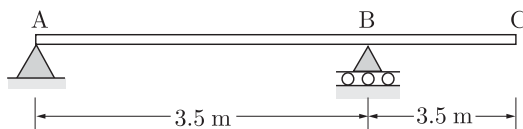

- Q. 9 With reference to the plane frame (portal with overhanging beam) shown below, sketch four possible failure mechanisms, clearly marking the plastic hinge locations and mode of failure in each case. For the case of the 'combined mechanism', derive an expression for the collapse load W in terms of the plastic moment capacity M_P (assumed to be constant at all sections) and the dimension L .

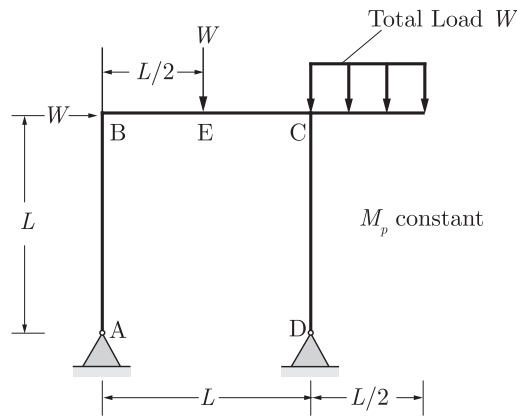

Q. 10

The relevant cross-sectional details of a compound beam comprising a symmetric I-section and a channel section (with welded connections), proposed for a steel gantry girder, are given below (all dimensions in mm).

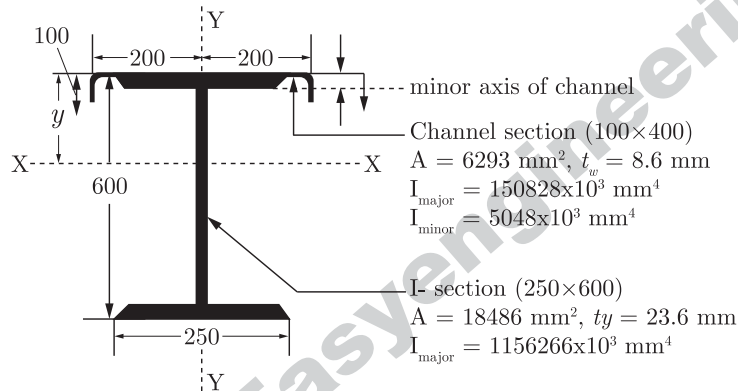

- Determine the depth of the centroidal axis \bar{y} and the second moments of area, I_{xx} and $I_{yy,eff}$ of the compound section. For computing $I_{yy,eff}$ include the full contribution of the channel section, but only the top flange of the I-section. (3)
- Determine the maximum compressive stress that develops at a top corner location on account of a vertical bending moment of 550.0 kNm, combined with a horizontal bending moment of 15.0 kNm. (2)

Q. 11

- For what type of soils would you use falling head and constant head permeability tests to determine the coefficients of permeability. (1)
- Derive the formula to estimate the coefficient of permeability from falling head permeability test. (3)
- Estimate the flow quantity (in litres per second) through the soil in the pipe shown below. The pressure heads at two locations are shown in the figure. The internal diameter of the pipe is 1 m and the coefficient of permeability of soil is $1 \times 10^{-5} \text{ m/sec}$.

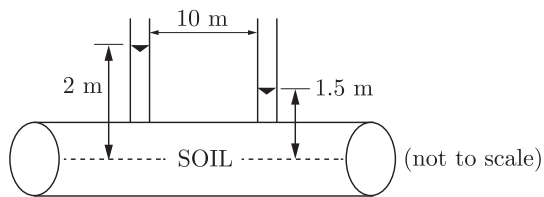

Q. 12

(a) Referring to consolidated-undrained (C-U) triaxial compression tests, sketch the total stress and the corresponding effective stress Mohr circles along with the failure envelopes for the following soils.

- (i) normally consolidated clays
- (ii) over consolidated clays

Clearly mark the total stress and the effective stress shear strength parameters on the figures. With respect to the slope stability analysis of embankments, when are the total and effective stress parameters used. (3)

(b) A C-U triaxial compression test was performed on saturated sand at a cell pressure of 100 kPa. The ultimate deviator stress was 350 kPa and the pore pressure at the peak stress was -40 kPa (suction). Estimate the total and effective stress shear strength parameters. (2)

Q. 13

A concrete gravity type retaining wall, shown below, retains granular soil having a friction angle of 35° and dry and saturated unit weights of 16 kN/m^3 and 20 kN/m^3 . The unit weights of concrete and water are 24 kN/m^3 and 10 kN/m^3 respectively. The friction factor at the base of the wall against lateral sliding is 0.47. Calculate the following quantities for the retaining wall.

- (i) Factor of safety against lateral sliding,
- (ii) Factor of safety against overturning, and
- (iii) Bearing pressure on foundation soil using Meyerhoffs method. (5)

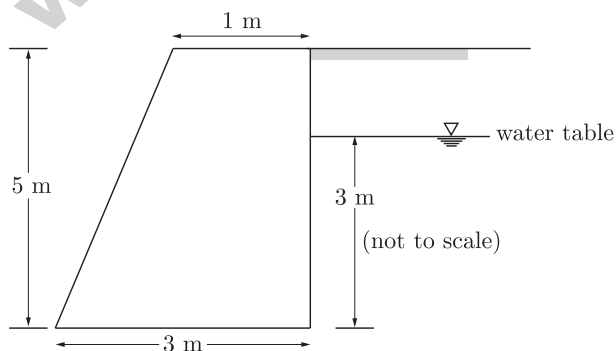

Q. 14

A group of 16 piles (4 in each row) was installed in a layered clay soil deposit shown below. The diameter of each pile is 500 mm and their c/c distance is 1 m. The length of the pile group is 18 m. Estimate the safe load capacity of the group with a factor of safety of 2.50. The adhesion factors (α) between the pile and soil in each soil layer are shown in the figure.

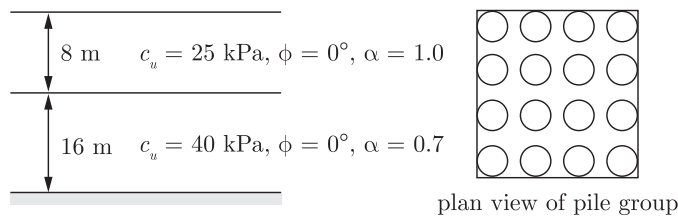

Q. 15 A spillway has its crest at elevation of +144.0 m and a horizontal apron at an elevation of +105.0 m on the downstream side. Find the tail water elevation required to form a hydraulic jump when the elevation of energy line above the crest is +146.5 m. The C_d for the flow can be assumed as 0.73. the energy loss over the spillway face may be neglected. (5)

Q. 16 The 4-hour unit hydrograph (UH) for a catchment having an area of 536 km² is shown in the Table below. Find the peak discharge when a 3-hour period of rainfall excess with intensity of 6 mm/hr was realised in the catchment. Assume that there is no base flow. (5)

Time (hours)	UH ordinate (m ³ /sec)	Time (hours)	UH ordinate (m ³ /sec)
0	0	11	73
1	10	12	59
2	60	13	48
3	120	14	36
4	170	15	28
5	200	16	20
6	180	17	13
7	150	18	8
8	124	19	3
9	104	20	0
10	88	21	0

Q. 17 A well of 300 mm diameter is located in a confined aquifer of 40 m thick. The aquifer has a hydraulic conductivity of 25 m/day and the radius of influence is 300 m. Determine the discharge in m³/hour from the well if the draw down is 3 m. Also determine the percentage increase in discharge if the diameter is made to 450 mm, with other conditions remain same. (5)

Q. 18 An area of 40000 ha. has to be irrigated by a canal for growing banana in 15000 ha. and 25000 ha, for growing paddy. The peak water requirements of banana and paddy 12 cm/month and 16 cm/month respectively and these peak demands occur at the same month. Design a suitable canal section using Lacey's method. Adopt a side slope of 0.5H : IV. (5)

Q. 19 A wastewater treatment plant discharges 1.5 m³/sec of effluent having an ultimate BOD of 40.0 mg/lit into a stream flowing at 10 m³/sec. Just upstream of the discharge point, the stream has an ultimate BOD of 3.0 mg/lit. The deoxygenation constant to the base 'e' is estimated as 0.32/day.

(a) Assuming complete mixing, find the ultimate BOD of the mixture of waste and stream just downstream of the outfall. (2)

(b) Assuming a constant cross-section area for the stream equal of 50 m^2 , estimate the BOD of the stream at a point 2.5 km downstream from the outfall. (3)

Q. 20 The data of an activated sludge process are as follows:

MLSS = 5000 mg/lit

Flow = $0.15 \text{ m}^3/\text{sec}$

SS of inflow = 400 mg/lit

Solids settled after 30 min = 25%

Volume of Aeration Tank = 3000 m^3

Sludge Wastage Rate = $120 \text{ m}^3/\text{day}$ with

VSS of 15000 mg/lit .

Calculate Sludge Volume Index (SVI), Sludge Density Index (SDI), Return Sludge Ratio (Q_r/Q) and Mean cell residence time (θ). (5)

Q. 21 The speeds of overtaking and overtaken vehicles on a highway are 85 kmph and 70 kmph respectively. Calculate the overtaking sight-distance needed for two way traffic. Assume the acceleration of the overtaking vehicle at $2.5 \text{ kmph per second}$ and the speed of the vehicle in the opposite direction as 85 kmph. (5)

Q. 22 Calculate the spacing between contraction joints for a two lane 250 mm thick concrete road having 3.5 m wide slab. Unit weight of concrete = 24 kN/m^3 . Ultimate stress in tension = 0.16 N/mm^2 . Coefficients of Friction at interface = 1.5, and the Factor of Safety = 2. Also calculate the spacing between expansion joints if the increase in temperature is 20°C , the expansion joint gap is 24 mm and the thermal coefficient = $10 \times 10^{-6} \text{ per}^\circ\text{C}$. (5)

ANSWER KEY

2001									
1.1	1.2	1.3	1.4	1.5	1.6	1.7	1.8	1.9	1.10
(A)	(A)	(D)	(C)	(C)	(B)	(D)	(B)	(*)	(A)
1.11	1.12	1.13	1.14	1.15	1.16	1.17	1.18	1.19	1.20
(D)	(B)	(A)	(C)	(B)	(A)	(B)	(C)	(B)	(D)
1.21	1.22	1.23	1.24	1.25					
(C)	(B)	(D)	(B)	(D)					
2.1	2.2	2.3	2.4	2.5	2.6	2.7	2.8	2.9	2.10
(B)	(D)	(C)	(A)	(D)	(D)	(C)	(B)	(B)	(D)
2.11	2.12	2.13	2.14	2.15	2.16	2.17	2.18	2.19	2.20
(B)	(D)	(A)	(D)	(C)	(D)	(A)	(B)	(*)	(D)
2.21	2.22	2.23	2.24	2.25					
(B)	(D)	(B)	(C)	(B)					