

Civil Engineering

Q. No. 1 – 25 Carry One Mark Each

1. Consider a rigid retaining wall with partially submerged cohesionless backfill with a surcharge. Which one of the following diagrams closely represents the Rankine's active earth pressure distribution against this wall?

(A)

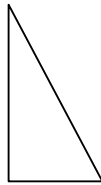

(B)



(C)



(D)



Key: (B)

2. The VPI (vertical point of intersection) is 100 m away (when measured along the horizontal) from the VPC (vertical point of curvature). If the vertical curve is parabolic, the length of the curve (in meters and measured along the horizontal) is _____

Key: (200)

Exp: VPI is horizontally midway between VPC and VPT

$$VPC = VPI - L/2$$

$$\Rightarrow 0 = 100 - L/2$$

$$\Rightarrow L = 200\text{m}$$

3. For a construction project. The mean and standard deviation of the completion time are 200 days and 6.1 days, respectively. Assume normal distribution and use the value of standard normal deviate $Z = 1.64$ for the 95% confidence level. The maximum time required (in days) for the completion of the project would be _____

Key: (210)

Exp:
$$z = \frac{T_s - T_E}{\sigma}$$

For 95% confidence level $z = 1.64$

$$T_E = 200 \text{ days}$$

$$\sigma = 6.1 \text{ days}$$

$$T_s = T_E + z\sigma = 200 + 1.64 \times 6.1 = 200 + 10.004 = 210.004 \text{ days}$$

4. Given that the scope of the construction work is well-defined with all its drawings, specifications, quantities and estimates, which one of the following types of contract would be most preferred?
- (A) EPC contract (B) Percentage rate contract
(C) Item rate contract (D) Lump sum contract

Key: (D)

5. The divergence of the vector field $V = x^2i + 2y^3j + z^4k$ at $x = 1, y = 2, z = 3$ is _____

Key: (134)

Exp: Given

$$v = x^2i + 2y^3j + z^4k$$

$$\text{div } v = \frac{\partial}{\partial x}(x^2) + \frac{\partial}{\partial y}(2y^3) + \frac{\partial}{\partial z}(z^4)$$

$$= 2x + 6y^2 + 4z^3$$

$$\text{div } v|_{(1,2,3)} = 2 + 24 + 108 = 134$$

6. Consider the frame shown in the figure:

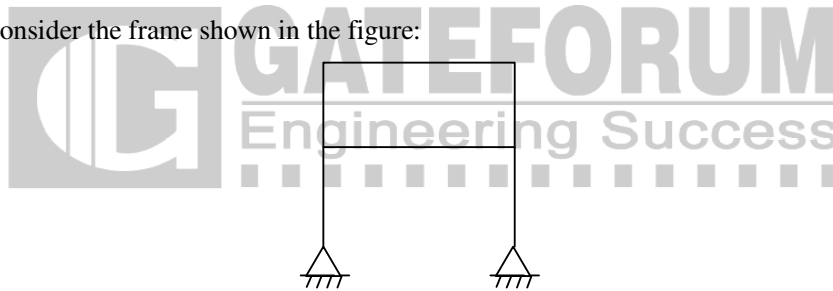

If the axial and shear deformations in different members of the frame are assumed to be negligible, the reduction in the degree of kinematical indeterminacy would be equal to

- (A) 5 (B) 6 (C) 7 (D) 8

Key: (B)

Exp:

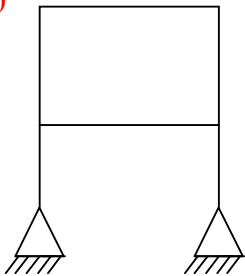

$$\text{Total degree of freedom} = 3j - R$$

$$J = \text{no. of joints} = 6$$

$$R = \text{no. of reactions} = 2 + 2 = 4$$

$$\text{DOF} = 3 \times 6 - 4 = 18 - 4 = 14$$

$$\text{When axial deformations are neglected total axial deformations} = 8$$

$$\text{Reduction in } D_k = 14 - 8 = 6$$

7. As per Noise Pollution (Regulation and Control) Rules 2000 of India, the day time noise limit for a residential zone, expressed in dB (A) L_{eq} , is
 (A) 55 (B) 65 (C) 75 (D) 85

Key: (A)

8. Let G be the specific gravity of soil solids, w the water content in the soil sample, γ_w the unit weight of water, and γ_d the dry unit weight of the soil. The equation for the zero air voids line in a compaction test plot is
 (A) $\gamma_d = \frac{G\gamma_w}{1+Gw}$ (B) $\gamma_d = \frac{G\gamma_w}{Gw}$ (C) $\gamma_d = \frac{Gw}{1+\gamma_w}$ (D) $\gamma_d = \frac{Gw}{1-\gamma_w}$

Key: (A)

Exp: From zero air void line

$$\gamma_d = \frac{G \cdot \gamma_w}{1 + wG}$$

9. The safety within a roundabout and the efficiency of a roundabout can be increased, respectively, by
 (A) increasing the entry radius and increasing the exit radius
 (B) increasing the entry radius and decreasing the exit radius
 (C) decreasing the entry radius and increasing the exit radius
 (D) decreasing the entry radius and decreasing the exit radius

Key: (C)

10. In a material under a state of plane strain, a 10×10 mm square centered at a point gets deformed as shown in the figure.

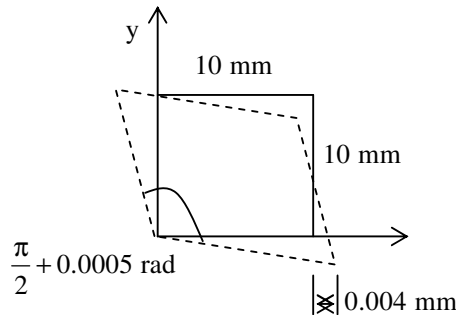

If the shear strain γ_{xy} at this point is expressed as $0.001k$ (in rad), the value of k is

- (A) 0.50 (B) 0.25 (C) -0.25 (D) -0.50

Key: (D)

Exp: Shear strain in an element is positive when the angle between two faces is reduced and negative when angle is increased.

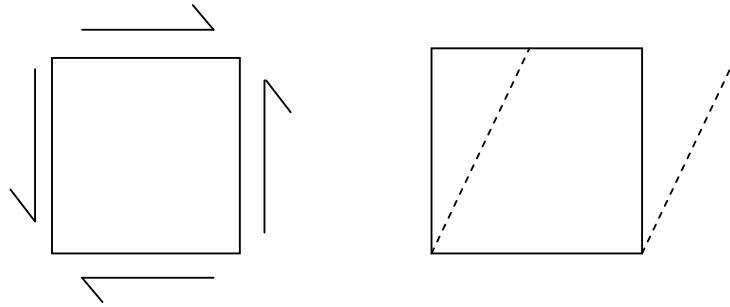

Here since angle has increased, so shear strain should be negative.

$$Y_{xy} = -0.0056 \text{ rad} = 0.001k$$

$$\text{So, } -0.005 = 0.001 K$$

$$\Rightarrow K = -0.50$$

11. The method of orientation used, when the plane table occupies a position not yet located on the map, is called as

(A) traversing (B) radiation (C) levelling (D) resection

Key: (D)

Exp: Resection is the method of orientation used when the table occupies a position not yet located in the map.

12. If a centrifugal pump has an impeller speed of N (in rpm), discharge Q (in m^3/s) and the total head H (in m), the expression for the specific speed N_s of the pump is given by

(A) $N_s = \frac{NQ^{0.5}}{H^{0.5}}$ (B) $N_s = \frac{NQ^{0.5}}{H}$ (C) $N_s = \frac{NQ^{0.5}}{H^{0.75}}$ (D) $N_s = \frac{NQ}{H^{0.75}}$

Key: (C)

Exp: The specific speed of pump $(N_s) = \frac{N\sqrt{Q}}{H^{3/4}} = \frac{N \cdot Q^{0.5}}{H^{0.75}}$

13. Following observations have been made for the elevation and temperature to ascertain the stability of the atmosphere:

Elevation (in m)	Temperature (in °C)
10	15.5
60	15.0
130	14.3

The atmosphere is classified as

(A) Stable (B) Unstable (C) Neutral (D) Inverse

Key: (C)

Exp: $\frac{\Delta T}{\Delta Z} = \frac{15-15.5}{60-10} = -\frac{0.5}{50} = -\frac{1.00^\circ\text{C}}{100\text{m}}$
 $\frac{\Delta T}{\Delta Z} = \frac{14.3-15.0}{130-60} = -\frac{0.7}{70} = -\frac{1.00^\circ\text{C}}{100\text{m}}$

So, Neutral

14. During a storm event in a certain period, the rainfall intensity is 3.5 cm/hour and the Φ - index is 1.5 cm/hour. The intensity of effective rainfall (in cm/hour, up to one decimal place) for this period is _____

Key: (2)

Exp: $\phi - \text{index} = \frac{P - R}{t}$
 $1.5 = \frac{3.5 - R}{1} \Rightarrow R = 3.5 - 1.5 = 2 \text{ cm/hr}$

15. For a broad gauge railway track on a horizontal curve of radius R (in m), the equilibrium cant e required for a train moving at a speed of V (in km per hour) is

(A) $e = 1.676 \frac{V^2}{R}$ (B) $e = 1.315 \frac{V^2}{R}$
 (C) $e = 0.80 \frac{V^2}{R}$ (D) $e = 0.60 \frac{V^2}{R}$

Key: (B)

Exp: Equilibrium cant = $\frac{G.V^2}{127R}$

For Broad gauge (G) = 1.676

$$e = \frac{1.676 V^2}{127 R}$$

$$= 0.01319 \frac{V^2}{R} \text{ m}$$

$$e = 1.319 \frac{V^2}{R} \text{ cm}$$

16. Consider the following simultaneous equations (with c_1 and c_2 being constants):

$$3x_1 + 2x_2 = c_1$$

$$4x_1 + x_2 = c_2$$

The characteristic equation for these simultaneous equations is

(A) $\lambda^2 - 4\lambda - 5 = 0$

(B) $\lambda^2 - 4\lambda + 5 = 0$

(C) $\lambda^2 + 4\lambda - 5 = 0$

(D) $\lambda^2 + 4\lambda + 5 = 0$

Key: (A)

Exp: given systems

$$3x_1 + 2x_2 = c_1$$

$$4x_1 + x_2 = c_2$$

$$\text{Matrix Form is } \begin{pmatrix} 3 & 2 \\ 4 & 1 \end{pmatrix} \begin{pmatrix} x_1 \\ x_2 \end{pmatrix} = \begin{bmatrix} c_1 \\ c_2 \end{bmatrix}$$

$$AX = B$$

Characteristic equations of above systems is

$$|A - \lambda I| = 0$$

$$\begin{vmatrix} 3-\lambda & 2 \\ 4 & 1-\lambda \end{vmatrix} = 0$$

$$\text{By expanding } \lambda^2 - 4\lambda - 5 = 0$$

17. A sheet pile has an embedment depth of 12 m in a homogeneous soil stratum. The coefficient of permeability of soil is 10^{-6} m/s. Difference in the water levels between the two sides of the sheet pile is 4 m. The flow net is constructed with five number of flow lines and eleven number of equipotential lines. The quantity of seepage (in cm^3/s per m, up to one decimal place) under the sheet pile is _____

Key: (1.6)

Exp: $N_f = \text{No. of flow channels} = \text{No. of flow lines} - 1 = 5 - 1 = 4$

$N_d = \text{No. of equipotential drops} = \text{no. of equipotential lines} - 1 = 11 - 1 = 10$

$$q = k \cdot h \frac{N_f}{N_d}$$

$$= 10^{-6} \times 4 \times \frac{4}{10}$$

$$= 1.6 \times 10^{-6} \text{ m}^3/\text{s}$$

$$q = 1.6 \text{ cm}^3/\text{sec. per. m. width}$$

18. While aligning a hill road with a ruling gradient of 6 %, a horizontal curve of radius 50 m is encountered. The grade compensation (in percentage, up to two decimal places) to be provided for this case would be _____

Key: (1.5)

Exp: The grade compensation = $\frac{30 + R}{R} = \frac{30 + 50}{50} = 1.6\%$

$$\text{Maximum grade compensation} = \frac{75}{R} = \frac{75}{50} = 1.5\%$$

$$\text{Grade compensation} = 1.5$$

19. Consider the following statements related to the pore pressure parameters, A and B:

P. A always lies between 0 and 1.0

- Q. A can be less than 0 or greater than 1.0
 R. B always lies between 0 and 1.0
 S. B can be less than 0 or greater than 1.0

For these statements, which one of the following options is correct?

- (A) P and R (B) P and S (C) Q and R (D) Q and S

Key: (C)

20. Let the characteristic strength be defined as that value, below which not more than 50% of the results are expected to fall. Assuming a standard deviation of 4 MPa, the target mean strength (in MPa) to be considered in the mix design of a M25 concrete would be

- (A) 18.42 (B) 21.00 (C) 25.00 (D) 31.58

Key: (C)

Exp: For the given condition,

Target mean strength = characteristic strength = 25 MPa

21. The plate load test was conducted on a clayey strata by using a plate of 0.3m×0.3 m dimensions, and the ultimate load per unit area for the plate was found to be 180 kPa. The ultimate bearing capacity (in kPa) of a 2 m wide square footing would be

- (A) 27 (B) 180 (C) 1200 (D) 2000

Key: (B)

Exp: In plate load test,

The ultimate bearing capacity does not depends upon width of footing

$$q_{uf} = q_{up} = 180 \text{ kPa}$$

22. The infiltration capacity of a soil follows the Horton's exponential model, $f = c_1 + c_2 e^{-kt}$. During an experiment, the initial infiltration capacity was observed to be 200 mm/h. After a long time, the infiltration capacity was reduced to 25 mm/h. If the infiltration capacity after 1 hour was 90 mm/h, the value of the decay rate constant, k (in h^{-1} , up to two decimal places) is _____

Key: (0.99)

Exp: Horton's infiltration capacity $f = f_e + (f_o - f_e) e^{-\alpha t}$

f_e = ultimate infiltration capacity = 25 mm/hr

f_o = Initial infiltration capacity = 200 mm/hr

f = Infiltration capacity = 90 mm/hr

$$90 = 25 + (200 - 25) e^{-\alpha \times 1}$$

$$175 e^{-\alpha} = 65$$

$$e^{-\alpha} = 0.371$$

$$\alpha = 0.9915; \alpha = 0.99 / \text{hour}$$

23. A two-faced fair coin has its faces designated as head (H) and tail (T). This coin is tossed three times in succession to record the following outcomes: H, H, H. If the coin is tossed one

more time, the probability (up to one decimal place) of obtaining H again, given the previous realizations of H, H and H, would be _____

Key: (0.5)

Exp: Given first three are already heads. If the coin is tossed again, the outcome does not depend on previous outcomes.

$$\text{Probability getting head} = \frac{1}{2} = 0.5$$

(or)

probability of first three are heads

$$= P(H \times H \times H) = \frac{1}{2} \times \frac{1}{2} \times \frac{1}{2} = \frac{1}{8}$$

Probability of fourth time head is

$$= P(H \times H \times H \times H) = \frac{1}{2} \times \frac{1}{2} \times \frac{1}{2} \times \frac{1}{2} = \frac{1}{16}$$

Given condition is that (H.H.H) is already realized

$$\text{The required probability} = \frac{\frac{1}{16}}{\frac{1}{8}} = 0.5$$

24. The most important type of species involved in the degradation of organic matter in the case of activated sludge process is

- (A) Autotrophs (B) Heterotrophs (C) Prototrophs (D) Photo-autotrophs

Key: (B)

25. Let $w = f(x, y)$, where x and y are functions of t . Then, according to the chain rule, $\frac{dw}{dt}$ is equal to

(A) $\frac{dw}{dx} \frac{dx}{dt} + \frac{dw}{dy} \frac{dy}{dt}$

(B) $\frac{\partial w}{\partial x} \frac{\partial x}{\partial t} + \frac{\partial w}{\partial y} \frac{\partial y}{\partial t}$

(C) $\frac{\partial w}{\partial x} \frac{dx}{dt} + \frac{\partial w}{\partial y} \frac{dy}{dt}$

(D) $\frac{dw}{dx} \frac{\partial x}{\partial t} + \frac{dw}{dy} \frac{\partial y}{\partial t}$

Key: (C)

Exp: $w = f(x, y)$ where x and y are functions of t .

By Chain Rule

$$\frac{dw}{dt} = \frac{\partial w}{\partial x} \cdot \frac{dx}{dt} + \frac{\partial w}{\partial y} \cdot \frac{dy}{dt}$$

Q. No. 26 to 55 Carry Two Marks Each

26. Consider the portal frame shown in the figure and assume the modulus of elasticity $E = 2.5 \times 10^4$ MPa and the moment of inertia, $I = 8 \times 10^8$ mm⁴ for all the members of the frame.

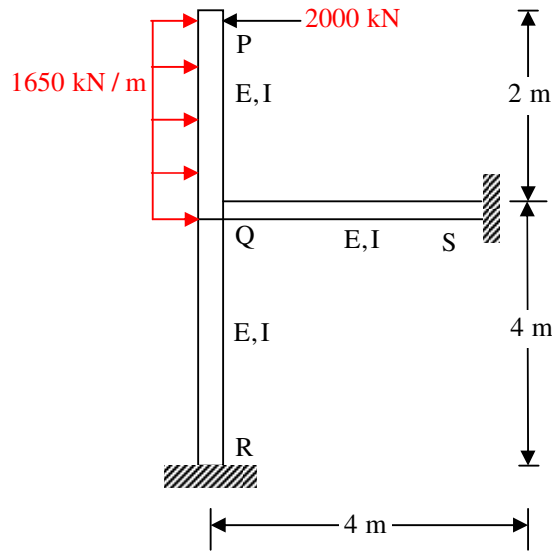

The rotation (in degrees, up to one decimal place) at the rigid joint Q would be _____

Key: (1.003)

Exp: Moment at θ , $M_{\theta} = 2000 \times 2 - 1650 \times \frac{(2)^2}{2}$
 $= 700 \text{ kN-m anticlockwise}$

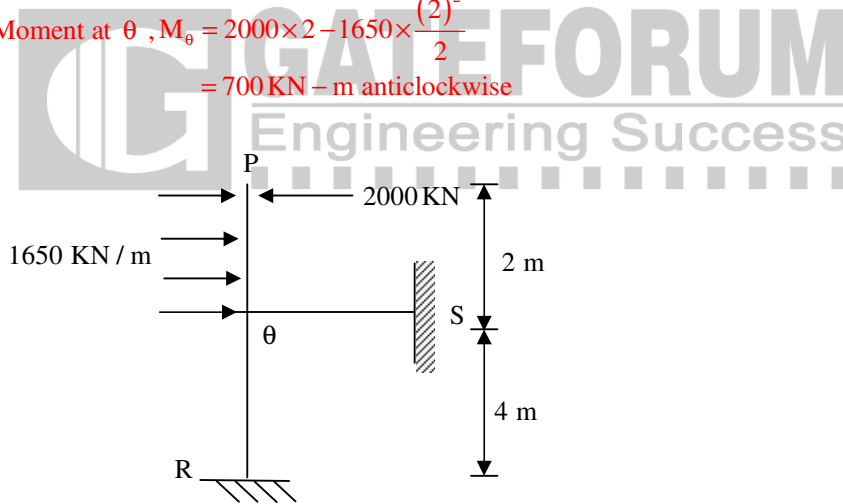

$$K_{\theta R} = \frac{uEI}{4} = EI,$$

$$K_{\theta S} = \frac{uEI}{4} = EI$$

$$K_{\theta} = K_{\theta R} + K_{\theta S} = 2EI$$

$$\therefore M_{\theta} = K_{\theta} \theta_{\theta}$$

$$\therefore \theta_{\theta} = \frac{M_{\theta}}{K_{\theta}} = \frac{700 \times 10^6 \times 1000}{2 \times 2.5 \times 10^4 \times 10^8}$$

$$= 0.0175 \text{ rad}$$

$$= 1.003^{\circ} \approx 1^{\circ}$$

27. The radii of relative stiffness of the rigid pavements P and Q are denoted by ℓ_p and ℓ_Q , respectively. The geometric and material properties of the concrete slab and underlying soil are given below:

Pavement	Concrete					Soil
	Length of Slab	Breadth of Slab	Thickness of Slab	Modulus of Elasticity	Poisson's Ratio	Sub grade Reaction Modulus
P	L	B	h	E	μ	K
Q	L	B	0.5h	E	μ	2K

The ratio (up to one decimal place) of ℓ_p/ℓ_Q is _____

Key: (2)

Exp: Radius of relative stiffness (ℓ) = $\left[\frac{Eh^3}{12K(1-\mu^2)} \right]^{1/4}$

$$\frac{\ell_p}{\ell_Q} = \frac{\left[\frac{Eh^3}{12K(1-\mu^2)} \right]^{1/4}}{\left[\frac{E(0.5h)^3}{12 \times 2K \times (1-\mu^2)} \right]^{1/4}} = \left[\frac{2}{(0.5)^3} \right]^{1/4} = (2^4)^{1/4} = 2$$

28. A 1 m wide rectangular channel carries a discharge of $2\text{m}^3/\text{s}$. The specific energy-depth diagram is prepared for the channel. It is observed in this diagram that corresponding to a particular specific energy, the subcritical depth is twice the supercritical depth. The subcritical depth (in meters, up to two decimal places) is equal to _____

Key: (1.069)

Exp: Given sub critical depth = $2 \times$ super critical depth

$y =$ super critical depth

Sub critical depth = $2y$

$$E_1 = E_2$$

$$y_1 + \frac{Q_1^2}{2gA_1^2} = y_2 + \frac{Q_2^2}{2gA_2^2}$$

$$2y + \frac{Q^2}{2gB^2(2y)^2} = y + \frac{Q^2}{2g \cdot B^2 y^2}$$

$$y = \frac{Q^2}{2gB^2} \left[\frac{-1}{(2y)^2} + \frac{1}{y^2} \right]$$

$$y = \frac{2^2}{2 \times 9.81 \times 1} \left[-\frac{1}{4} + 1 \right] \frac{1}{y^2} \Rightarrow y^3 = 0.153 \Rightarrow y = 0.534$$

Super critical depth (y) = 0.5347

Subcritical depth = $2y = 2 \times 0.5347 = 1.0694\text{m}$

29. A hollow circular shaft has an outer diameter of 100 mm and inner diameter of 50 mm. If the allowable shear stress is 125 MPa, the maximum torque (in kN-m) that the shaft can resist is _____

Key: (23.009)

Exp: $\frac{T_1}{J} = \frac{\tau}{r}$

$$T = \frac{\tau}{r} J$$

$$= \frac{125}{\left(\frac{100}{2}\right)} \left[\frac{\pi}{32} (D_o^4 - D_i^4) \right]$$

$$= \frac{125 \times 2}{100} \left[\frac{\pi}{32} (100^4 - 50^4) \right]$$

$$= 23009711.82 \text{ N-m}$$

$$= 23.009 \text{ kN-m}$$

30. Consider the following statements:

- P. Walls of one brick thick are measured in square meters.
- Q. Walls of one brick thick are measured in cubic meters.
- R. No deduction in the brickwork quantity is made for openings in walls up to 0.1 m² area.
- S. For the measurement of excavation from the borrow pit in a fairly uniform ground, dead men are left at suitable intervals.

For the above statements, the correct option is

- (A) P-False; Q-True; R- False; S-True
- (B) P-False; Q-True; R-False; S-False
- (C) P-True; Q-False; R-True; S- False
- (D) P-True; Q-False; R-True; S-True

Key: (D)

31. Following are the statements related to the stress paths in a triaxial testing of soils:

- P. If $\sigma_1 = \sigma_3$, the stress point lies at the origin of the p-q plot
- Q. If $\sigma_1 = \sigma_3$, the stress point lies on the p-axis of the p-q plot.
- R. If $\sigma_1 > \sigma_3$, both the stress points p and q are positive.

For the above statements, the correct combination is

- (A) P – False; Q – True; R – True
- (B) P – False; Q – True; R – True
- (C) P – False; Q – True; R – False
- (D) P – True; Q – False; R – False

Key: (A)

Exp:

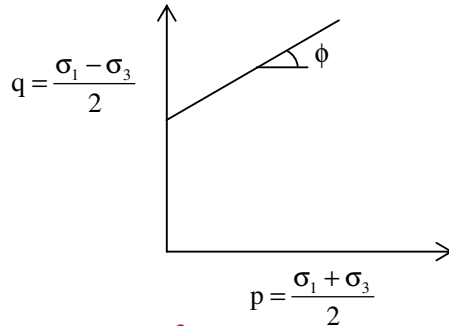

If $\sigma_1 = \sigma_3 \Rightarrow P = \frac{2\sigma_1}{2} = \sigma_1, q = 0$

\therefore lies on P-axis

If $\sigma_1 > \sigma_3 \Rightarrow P = \frac{\sigma_1 + \sigma_3}{2} > 0, q = \frac{\sigma_1 - \sigma_3}{2} > 0.$

p & q are positive

32. A simply supported rectangular concrete beam of span 8m has to be prestressed with a force of 1600kN. The tendon is of parabolic profile having zero eccentricity at the supports. The beam has to carry an external uniformly distributed load of intensity 30 kN/m. Neglecting the self-weight of the beam, the maximum dip (in meters, up to two decimal places) of the tendon at the mid-span to balance the external load should be _____

Key: (0.15)

Exp:

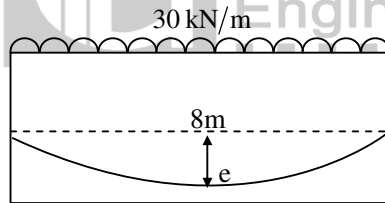

Maximum moment = Pe

$$\frac{wl^2}{8} = Pe$$

$$e = \frac{wl^2}{8P} = \frac{30 \times 8^2}{8 \times 1600} = 0.15 \text{ m}$$

33. An observer standing on the deck of a ship just sees the top of a lighthouse. The top of the lighthouse is 40 m above the sea level and the height of the observer's eye is 5 m above the sea level. The distance (in km, up to one decimal place) of the observer from the lighthouse is _____

Key: (33)

Exp: $0.0673d_1^2 = 5 \Rightarrow d_1 = 8.62 \text{ Km}$

$0.0673d_2^2 = 40 \Rightarrow d_2 = 24.38 \text{ Km}$

Therefore distance of observer from light house

$$\begin{aligned} d &= d_1 + d_2 \\ &= 8.62 + 24.38 \\ &= 33 \text{ km} \end{aligned}$$

34. If $A = \begin{bmatrix} 1 & 5 \\ 6 & 2 \end{bmatrix}$ and $B = \begin{bmatrix} 3 & 7 \\ 8 & 4 \end{bmatrix}$, AB^T is equal to

(A) $\begin{bmatrix} 38 & 28 \\ 32 & 56 \end{bmatrix}$

(B) $\begin{bmatrix} 3 & 40 \\ 42 & 8 \end{bmatrix}$

(C) $\begin{bmatrix} 43 & 27 \\ 34 & 50 \end{bmatrix}$

(D) $\begin{bmatrix} 38 & 32 \\ 28 & 56 \end{bmatrix}$

Key: (A)

Exp: $A = \begin{pmatrix} 1 & 5 \\ 6 & 2 \end{pmatrix}$ $B = \begin{pmatrix} 3 & 7 \\ 8 & 4 \end{pmatrix}$

$$AB^T = \begin{pmatrix} 1 & 5 \\ 6 & 2 \end{pmatrix} \begin{pmatrix} 3 & 8 \\ 7 & 4 \end{pmatrix}$$

$$= \begin{bmatrix} 38 & 28 \\ 32 & 56 \end{bmatrix}$$

35. A 2 m long, axially loaded mild steel rod of 8 mm diameter exhibits the load-displacement ($p-\delta$) behavior as shown in the figure.

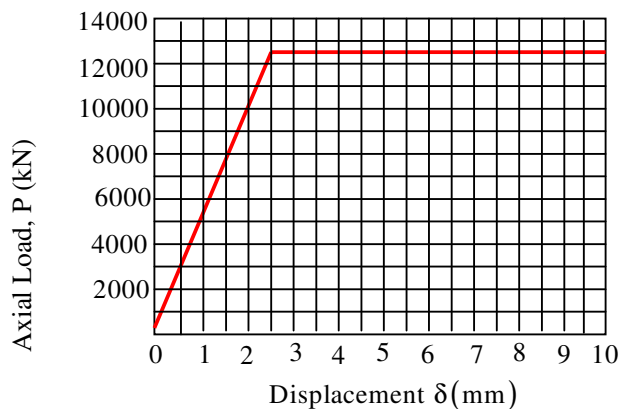

Assume the yield stress of steel as 250 Mpa. The complementary energy (in N-mm) stored in the bar up to its linear elastic behavior will be _____

Key: (15707.963)

Exp: Strain up to linear elastic behaviour is

$$\epsilon = \frac{\delta}{l} = \frac{2.5}{2000} = \frac{1}{800}$$

$$\begin{aligned}
 \text{Strain energy} &= \frac{1}{2} \times f_y \times \epsilon \times V \\
 &= \frac{1}{2} \times 250 \times \frac{1}{800} \times \left(2000 \times \frac{\pi}{4} \times 8^2 \right) \\
 &= 5000\pi \\
 &= 15707.963 \text{ Nmm}
 \end{aligned}$$

36. Two cars P and Q are moving in a racing track continuously for two hour. Assume that no other vehicles are using the track during this time. The expressions relating the distance travelled d (in km) and time t (in hour) for both the vehicles are given as

$$P:d = 60t$$

$$Q:d = 60t^2$$

Within the first one hour, the maximum space headway would be

- (A) 15 km at 30 minutes (B) 15 km at 15 minutes
 (C) 30 km at 30 minutes (D) 30 km at 15 minutes

Key: (A)

Exp: P: $d = 60t$, Q : $d = 60t^2$

Distance at any time t between P and Q is given by $d(t) = 60t - 60t^2$

For space headway to be maximum

$$\frac{d^2}{dt^2}(d(t)) = 0$$

$$\Rightarrow 60t - 120t = 0$$

$$\Rightarrow t = 1/2 \text{ hour}$$

$$\text{so, } d(1/2) = 60 \times 1/2 - 60 \times \left(\frac{1}{2}\right)^2 = 30 - 15 = 15 \text{ km}$$

So, space headway would be max at $t = 30$ minutes

37. Consider the following definite integral:

$$I = \int_0^1 \frac{(\sin^{-1} x)^2}{\sqrt{1-x^2}} dx$$

The value of the integral is

- (A) $\frac{\pi^3}{24}$ (B) $\frac{\pi^3}{12}$ (C) $\frac{\pi^3}{48}$ (D) $\frac{\pi^3}{64}$

Key: (A)

Exp: given $I = \int_0^1 \frac{(\sin^{-1} x)^2}{\sqrt{1-x^2}} dx$

$$\begin{aligned}
 &= \left. \frac{(\sin^{-1} x)^3}{3} \right|_0^1 \quad \left(\because \int f^n(x) f'(x) dx \right. \\
 &\quad \left. = \frac{f^{n+1}}{n+1} \right) \\
 &= \frac{1}{3} [(\sin^{-1})^3 - \sin^{-1} 0] = \frac{1}{3} \left[\left(\frac{\pi}{2} \right)^3 - 0 \right] = \frac{\pi^3}{24}
 \end{aligned}$$

38. A municipal corporation is required to treat 1000 m³/day of water. It is found that an overflow rate of 20 m/day will produce a satisfactory removal of the discrete suspended particles at a depth of 3 m. The diameter (in meters, rounded to the nearest integer) of a circular settling tank designed for the removal of these particles would be _____

Key: (8)

Exp: Detention time of a circular tank is given by

$$t_d = \frac{d^2 (0.011d + 0.785H)}{Q}$$

$$\text{So, } \frac{d^2 (0.011d + 0.785H)}{Q} = \frac{3}{20}$$

$$\Rightarrow \frac{d^2 (0.011d + 0.785 \times 3)}{1000} = \frac{3}{20}$$

$$\Rightarrow 0.011d^3 + 2.355d^2 - 150 = 0$$

$$\Rightarrow d = 7.83 \text{ m} \approx 8 \text{ m (rounded to nearest integer)}$$

39. For the construction of a highway. A cut is to be made as shown in the figure.

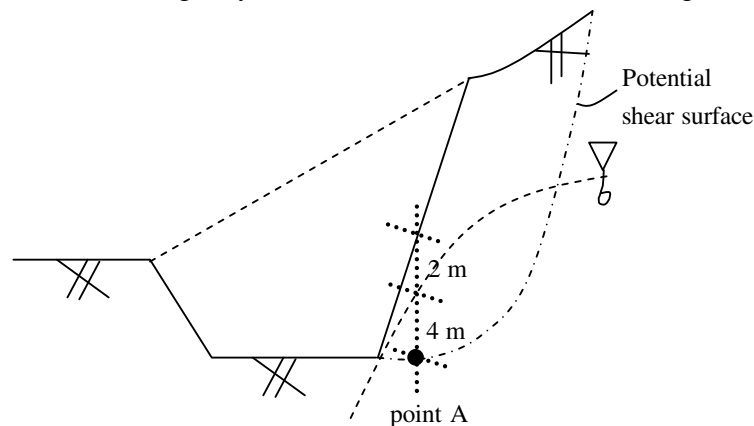

The soil exhibits $c' = 20 \text{ kPa}$, $\phi = 18^\circ$, and the undrained shear strength = 80 kPa. The unit weight of water is 9.81 kN/m^3 . The unit weights of the soil above and below the ground water table are 18 and 20 kN/m^3 , respectively. If the shear stress at Point A is 50 kPa, the factors of safety against the shear failure at this point, considering the undrained and drained conditions, respectively, would be

- (A) 1.6 and 0.9
(B) 0.9 and 1.6
(C) 0.6 and 1.2
(D) 1.2 and 0.6

Key: (A)

Exp: Case-I: Undrained condition

$$\begin{aligned} \text{F.O.S} &= \frac{\text{Resisting shear stress}}{\text{Actual shear stress}} \\ &= \frac{80}{50} = 1.6 \end{aligned}$$

Case-I: Drained condition

$$\begin{aligned} \text{F.O.S} &= \frac{\bar{\sigma} \tan \phi' + c'}{50} \\ &= \frac{[2 \times 18 + 4(20 - 9.81)] \times \tan 18^\circ + 20}{50} \\ &= 0.9 \end{aligned}$$

40. A catchment is idealized as a 25 km × 25 km square. It has five rain gauges, one at each corner and one at the center, as shown in the figure.

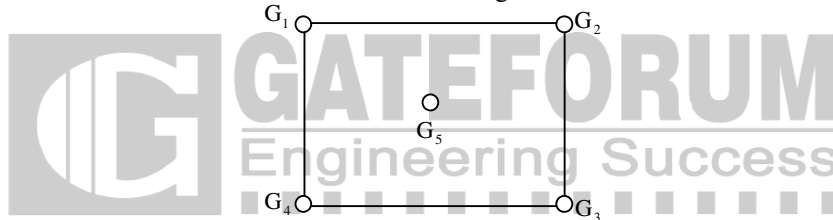

During a month, the precipitation at these gauges is measured as $G_1 = 300$ mm, $G_2 = 285$ mm, $G_3 = 272$ mm, $G_4 = 290$ mm and $G_5 = 288$ mm. The average precipitation (in mm, up to one decimal place) over the catchment during this month by using the Thiessen polygon method is _____

Key: (287.375)

Exp: By thiesen polygon method

$$P_{\text{avg}} = \frac{\sum P_i A_i}{\sum A_i}$$

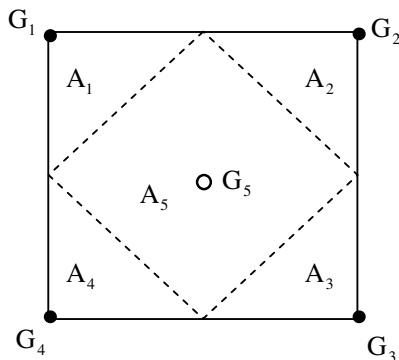

$$A_5 = \left(\frac{25}{\sqrt{2}}\right)^2 = 312.5 \text{ km}^2$$

$$A_1 = A_2 = A_3 = A_4 = \frac{625 - 312.5}{4} = 78.125 \text{ km}^2$$

$$P_{\text{avg}} = \frac{G_1 A_1 + G_2 A_2 + G_3 A_3 + G_4 A_4 + G_5 A_5}{A}$$

$$= \frac{300 \times 78.125 + 285 \times 78.125 + 272 \times 78.125 + 290 \times 78.125 + 288 \times 312.5}{625}$$

$$= 287.375 \text{ mm}$$

41. The tangent to the curve represented by $y = x \ln x$ is required to have 45° inclination with the x-axis. The coordinates of the tangent point would be
- (A) (1,0) (B) (0,1) (C) (1,1) (D) $(\sqrt{2}, \sqrt{2})$

Key: (A)

Exp: $y = x \ln x$

$$\frac{dy}{dx} = x \cdot \frac{1}{x} + \ln x$$

Given that $\theta = 45^\circ \Rightarrow \tan \theta = 1$

$$\frac{dy}{dx} = \tan \theta = 1$$

$$\text{ie } \Rightarrow x \cdot \frac{1}{x} + \ln x = 1 \Rightarrow 1 + \ln x = 1$$

$x = 1, y = 0$ satisfies

\therefore A is correct

42. Water is pumped at a steady uniform flow rate of $0.01 \text{ m}^3/\text{s}$ through a horizontal smooth circular pipe of 100 mm diameter. Given that the Reynolds number is 800 and g is 9.81 m/s^2 , the head loss (in meters, up to one decimal place) per km length due to friction would be_____

Key: (66.67)

Exp: head loss (h_f) = $\frac{fLQ^2}{12d^5}$

$$f = \frac{64}{R_e} = \frac{64}{800} = 0.08$$

$$h_f = \frac{0.08 \times (0.01)^2}{12 \times (0.1)^5} \times 1000$$

$$= 66.67 \text{ per km}$$

43. Group I given a list of test methods and test apparatus for evaluating some of the properties of ordinary Portland cement (OPC) and concrete. Group II gives the list of these properties.

Group I

- P. Le chatelier test
- Q. Vee-Bee test
- R. Blaine air permeability test
- S. The Vicat apparatus

Group II

- 1. Soundness of OPC
- 2. Consistency and setting time of OPC
- 3. Consistency or workability of concrete
- 4. Fineness of OPC

The correct match of the items in Group I with the items in Group II is

- (A) P-1, Q-3, R-4, S-2
- (B) P-2, Q-3, R-1, S-4
- (C) P-4, Q-2, R-4, S-1
- (D) P-1, Q-4, R-2, S-3

Key: (A)

Exp: P - Le chattier test - soundness of OPC

Q - Vee-Bee test – consistency or workability of concrete

R - Blaine air permeability test - Fineness of OPC

S - The vicat apparatus – consistency and setting time of OPC

44. The figure shows a U-tube having a 5 mm×5 mm square cross-section filled with mercury (specific gravity = 13.6) up to a height of 20 cm in each limb (open to the atmosphere).

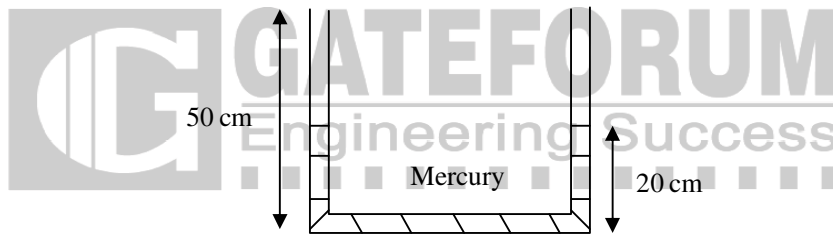

If 5cm³ of water is added to the right limb, the new height (in cm, up to two decimal places) of mercury in the LEFT limb will be _____

Key: (20.735)

Exp:

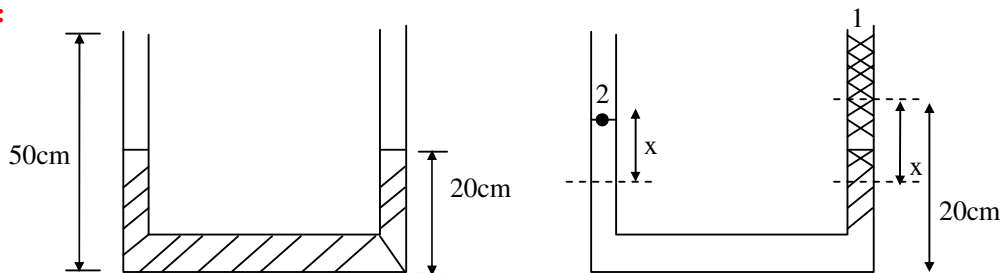

$$5\text{cm}^3 = 0.5 \times 0.5 \times \ell$$

$$\ell = 20\text{cm}$$

$$P_1 + (1000 \times 9.81 \times 0.2) - (13600 \times 9.81 \times 2x) = P_2 \quad P_1 = P_2$$

$$1000 \times 9.81 \times 0.2 = 13600 \times 9.81 \times 2x$$

$$x = \frac{100}{13600} = 7.35 \times 10^{-3} \text{m} = 0.735\text{cm}$$

$$\text{New height} = 20 + x = 20 + 0.735$$

$$= 20.735\text{cm}$$

44. The figure shows a U-tube having a 5 mm×5 mm square cross-section filled with mercury (specific gravity = 13.6) up to a height of 20 cm in each limb (open to the atmosphere).

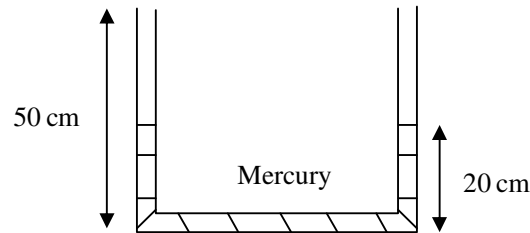

If 5 cm³ of water is added to the right limb, the new height (in cm, up to two decimal places) of mercury in the LEFT limb will be _____

Key: (20.735)

Exp:

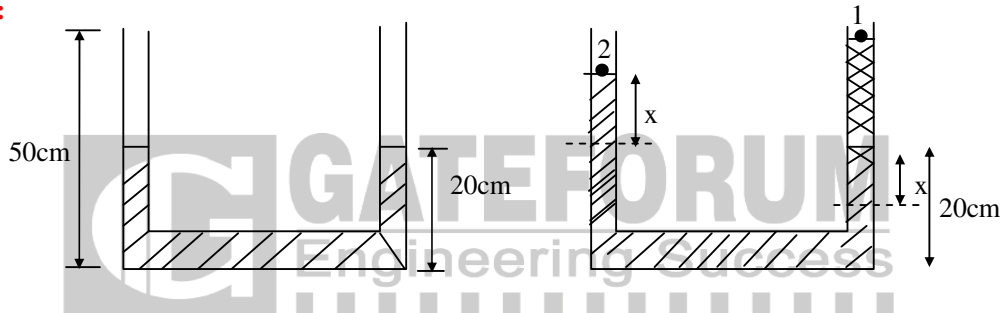

$$5 \text{ cm}^3 = 0.5 \times 0.5 \times \ell$$

$$\ell = 20 \text{ cm}$$

$$P_1 + (1000 \times 9.81 \times 0.2) - (13600 \times 9.81 \times 2x) = P_2$$

$$P_1 = P_2$$

$$1000 \times 9.81 \times 0.2 = 13600 \times 9.81 \times 2x$$

$$x = \frac{100}{13600} = 7.35 \times 10^{-3} \text{ m} = 0.735 \text{ cm}$$

$$\text{New height} = 20 + x = 20 + 0.735 = 20.735 \text{ cm}$$

45. The analysis of a water sample produces the following results:

Ion	Milligram per milli-equivalent for the ion	Concentration (mg/L)
Ca ²⁺	20.0	60
Mg ²⁺	12.2	36.6
Na ⁺	23.0	92
K ⁺	39.1	78.2
Cl ⁻	35.5	71
SO ₄ ²⁻	48.0	72
HCO ₃ ⁻	61.0	122

The total hardness (in mg/L as CaCO₃) of the water sample is _____

Key: (300)

Exp: Total hardness as $\text{CaCO}_3 = \left[\text{Ca}^{+2} \times \frac{50}{20} \right] + \left[\text{Mg}^{2+} \times \frac{50}{12.2} \right]$

$$= \left[60 \times \frac{50}{20} \right] + \left[36.6 \times \frac{50}{12.2} \right]$$

$$= 150 + 150 = 300 \text{ mg/L as } \text{CaCO}_3.$$

46. Consider the three prismatic beams with the clamped supports P, Q, and R as shown in the figures.

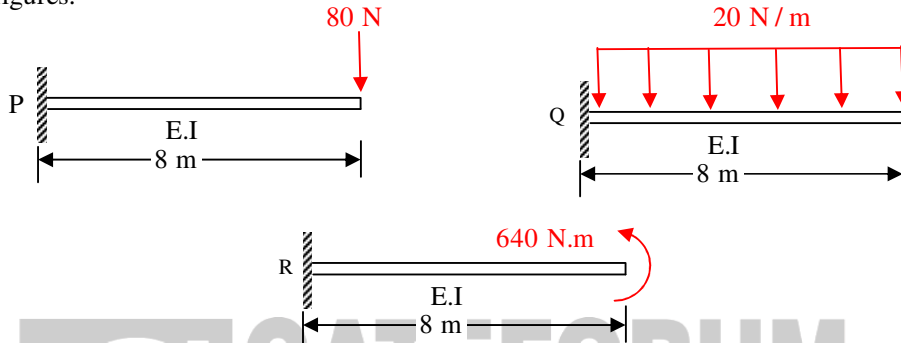

Given that the modulus of elasticity, E is 2.5×10^4 MPa; and the moment of inertia, I is $8 \times 10^8 \text{ mm}^4$, the correct comparison of the magnitudes of the shear forces S and the bending moment M developed at the supports is

- (A) $S_P < S_Q < S_R$; $M_P = M_Q = M_R$
 (B) $S_P = S_Q > S_R$; $M_P = M_Q > M_R$
 (C) $S_P < S_Q > S_R$; $M_P = M_Q = M_R$
 (D) $S_P < S_Q < S_R$; $M_P < M_Q < M_R$

Key: (C)

Exp:

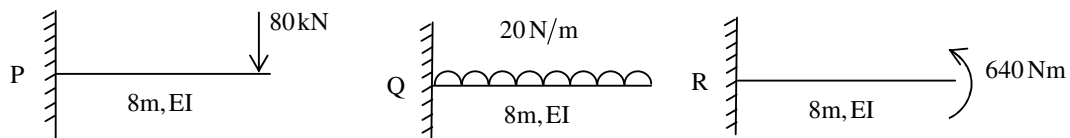

$$S_P = 80 \text{ N}$$

$$M_P = 80 \times 8 = 640 \text{ Nm}$$

$$S_Q = 20 \times 8 = 160 \text{ N}$$

$$M_Q = 20 \times 8 \times \frac{8}{2} = 640 \text{ Nm}$$

$$S_R = 0$$

$$M_R = 640 \text{ Nm}$$

$$S_P < S_Q > S_R \quad M_P = M_Q = M_R$$

47. Consider a square-shaped area ABCD on the ground with its centre at M as shown in the figure. Four concentrated vertical load of $P=5000$ kN are applied on this area, at each corner.

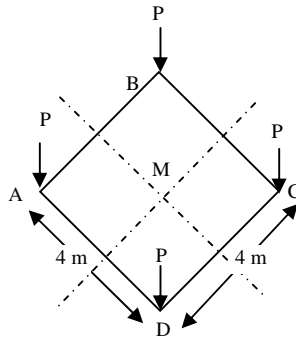

The vertical stress increment (in kPa, up to one decimal place) due to these loads according to the Boussinesq's equation, at a point 5 m right below M, is _____

Key: (191.36)

Exp:

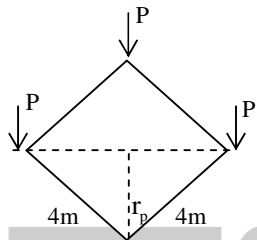

$$r = \frac{4}{\sqrt{2}} = 2\sqrt{2} = 2.82$$

$$\begin{aligned} \sigma_x &= 4 \times \frac{3Q}{2\pi z^2} \left[\frac{1}{1 + \left(\frac{r}{z}\right)^2} \right]^{-5/2} \\ &= 4 \times \frac{3 \times 5000}{2\pi \times 5^2} \left[\frac{1}{1 + \left(\frac{2.82}{5}\right)^2} \right]^{-5/2} \\ &= 191.36 \text{ kPa} \end{aligned}$$

48. For a given water sample, the ratio between $BOD_{5\text{-day}, 20^\circ\text{C}}$ and the ultimate BOD is 0.68. The value of the reaction rate constant k (on base e) (in day^{-1} , up to two decimal places) is _____

Key: (0.23)

Exp: $y = L_o [1 - e^{-K_D \times t}]$

$$\frac{y}{L_o} = 0.68$$

$$\frac{y}{L_o} = 1 - e^{-K_D \times t}$$

$$0.68 = 1 - e^{-K_D \times 5}$$

$$e^{-K_D \times 5} = 1 - 0.68 = 0.32$$

$$K_D = 0.2276 \approx 0.23 / \text{day}$$

49. Two identical concrete piles having the plan dimensions 50 cm × 50 cm are driven into a homogeneous sandy layer as shown in the figures. Consider the bearing capacity factor N_q for $\phi = 30^\circ$ as 24.

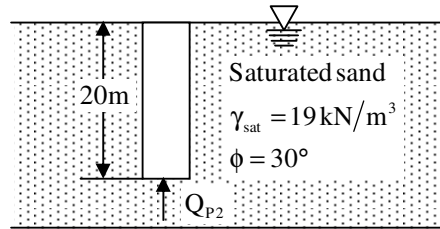
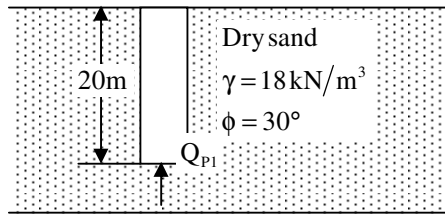

If Q_{p1} and Q_{p2} represent the ultimate point bearing resistance of the piles under dry and submerged conditions, respectively, which one of the following statements is correct ?

- (A) $Q_{p1} > Q_{p2}$ by about 100% (B) $Q_{p1} < Q_{p2}$ by about 100%
(C) $Q_{p1} > Q_{p2}$ by about 5% (D) $Q_{p1} < Q_{p2}$ about 5%

Key: (A)

50. The culturable command area of a canal is 10,000 ha. The area grows only two crops-rice in the Kharif season and wheat in the Rabi season. The design discharge of the canal is based on the rice requirements, which has an irrigated area of 2500 ha, base period of 150 days and delta of 130 cm. The maximum permissible irrigated area (in ha) for wheat, with a base period of 120 days and delta of 50 cm, is _____

Key: 5200

Exp: For rice,

$$\text{Duty} = \frac{8.64B}{\Delta} = \frac{8.6 \times 150}{1.30} = 996.923$$

$$Q = \frac{A}{D} = \frac{2500}{996.923} = 2.5077$$

For wheat

$$Q = \frac{A}{D} \Rightarrow A = Q.D = 2.5077 \times \frac{8.64 \times 120}{0.5} = 5200 \text{ ha}$$

51. The composition of a municipal solid waste sample is given below:

Component	Percent by Mass	Moisture Content	Energy content (kJ/kg, on as – discarded basis)
Food Waste	20	70	2500
Paper	10	4	10000
Cardboard	10	4	8000
Plastics	10	1	14000
Garden Trimmings	40	60	3500
Wood	5	20	14000
Tin Cans	5	2	100

The difference between the energy content of the waste sample calculated on dry basis and as-discarded basis (in kJ/kg) would be_____

Key: (3870)

Exp: Dry weight = Total weight –m.c

Component	% mass	M.C	Dry wt (%)	Energy content	Total Energy
Food waste	20	70	6	2500	50,000
Paper	10	4	9.6	10,000	1,00,000
Cardboard	10	4	9.6	8,000	80,000
Plastic	10	1	9.9	14,000	140000
Garden trim	40	60	16	3,500	140000
Wood	5	20	4	14,000	70000
Tin cans	5	2	4.9	100	500
			60		580500 KJ

$$\text{Unit energy} = \frac{580500}{100} = 5805 \text{ kJ/kg}$$

$$\text{Moisture content} = 100 - 60 = 40\%$$

$$\text{Energy on dry basis} = \frac{100 \times 5805}{100 - 40} = 9675 \text{ kJ/kg}$$

$$\text{So, different of energy} = 9675 - 5805 = 3870 \text{ kJ/kg}$$

52. Consider the following second-order differential equation:

$$y'' - 4y' + 3y = 2t - 3t^2$$

The particular solution of the differential equations is

- (A) $-2 - 2t - t^2$ (B) $-2t - t^2$ (C) $2t - 3t^2$ (D) $-2 - 2t - 3t^2$

Key: (A)

Exp: given $y'' - 4y' + 3y = 2t - 3t^2$

$$\Rightarrow (D^2 - 4D + 3)y = (2t - 3t^2)$$

By the definition of particular solution

$$y_p = \frac{1}{D^2 - 4D + 3} (2t - 3t^2)$$

$$\Rightarrow (D^2 - 4D + 3)y_p = 2t - 3t^2$$

verifying options, option (a) satisfies,

$$(D^2 - 4D + 3)(-2 - 2t - t^2)$$

$$= -2 + 8 + 8t - 6 - 6t - 3t^2 = 2t - 3t^2$$

∴ (A) is correct

Alternate solution:

Given

$$y'' - 4y' + 3y = 2t - 3t^2$$

$$(D^2 - 4D + 3)y = 2t - 3t^2$$

$$\text{Particular solution} = y_p = \frac{1}{D^2 - 4D + 3}(2t - 3t^2)$$

$$= \left[\frac{-1}{D-1} + \frac{1}{D-3} \right] (2t - 3t^2)$$

$$= \frac{1}{2} \left[\frac{1}{1-D} - \frac{1}{3-D} \right] 2 \left(t - \frac{3}{2}t^2 \right)$$

$$= \left[(1-D)^{-1} - \frac{1}{3} \left(1 - \frac{D}{3} \right)^{-1} \right] \left(t - \frac{3}{2}t^2 \right)$$

$$= (1 + D + D^2 + D^3 \dots) \left(t - \frac{3}{2}t^2 \right) - \frac{1}{3} \left(1 + \frac{D}{3} + \frac{D^2}{9} + \dots \right) \left(t - \frac{3}{2}t^2 \right)$$

$$= \left[t - \frac{3}{2}t^2 + 1 - 3t - 3 \right] - \frac{1}{3} \left[t - \frac{3}{2}t^2 + \frac{1-3t}{3} + \frac{1}{9}(-3) \right]$$

$$= -2 - 2t - \frac{3}{2}t^2 - \frac{t}{3} + \frac{1}{2}t^2 - \frac{1}{9} + \frac{t}{3} + \frac{1}{9} = -2 - 2t - t^2$$

53. Two plates of 8 mm thickness each are connected by a fillet weld of 6 mm thickness as shown in the figure.

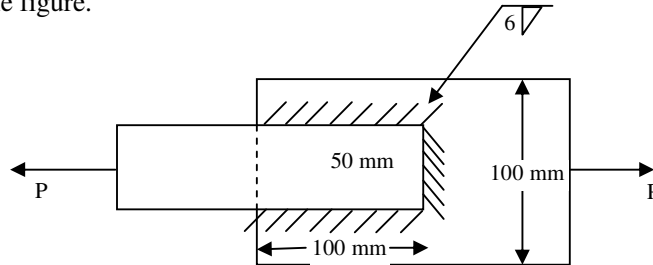

The permissible stresses in the plate and the weld are 150 MPa and 110 MPa, respectively.

Assuming the length of the weld shown in the figure to be the effective length, the permissible load P (in KN) is _____

Key: (60)

Exp:

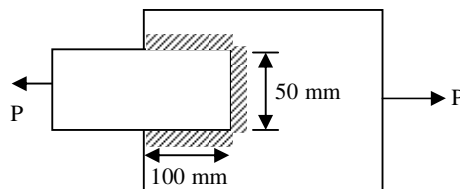

Maximum load taken by plate = $150 \times 50 \times 8 = 60\text{KN}$

= k.s left. τ

Maximum load taken by weld = $0.7 \times 6 \times (100 + 100 + 50) \times 110$

= 115.5KN

So, permissible load = min. Of {60KN, 115.5KN}

= 60KN

54. Two prismatic beams having the same flexural rigidity of 1000 kN-m^2 are shown in the figures.

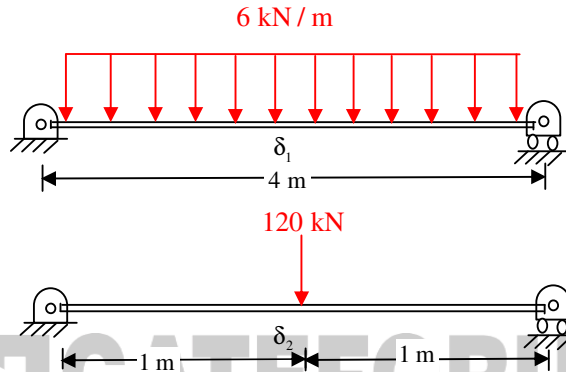

If the mid-span deflections of these beams are denoted by δ_1 and δ_2 (as indicated in the figures). The correct option is

- (A) $\delta_1 = \delta_2$ (B) $\delta_1 < \delta_2$ (C) $\delta_1 > \delta_2$ (D) $\delta_1 \gg \delta_2$

Key: (A)

Exp:

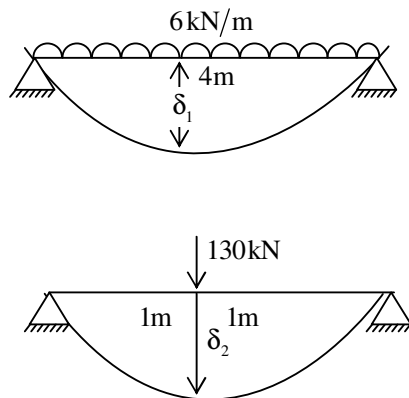

$$\delta_1 = \frac{5}{384} \frac{wL^4}{EI} = \frac{5}{384} \times \frac{6 \times 4^4}{1000} = \frac{1}{50} = 0.02\text{m}$$

$$\delta_2 = \frac{wL^3}{48EI} = \frac{130 \times 2^3}{48 \times 1000} = \frac{13}{600} = 0.02\text{m}$$

$$\delta_2 = \delta_1$$

55. Two towers A and B, standing vertically on a horizontal ground, appear in a vertical aerial photograph as shown in the figure.

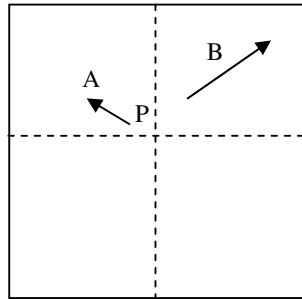

The length of the image of the tower A on the photograph is 1.5 cm and of the tower B is 2.0 cm. The distance of the top of the tower A (as shown by the arrowhead) is 4.0 cm and the distance of the top of the tower B is 6.0 cm, as measured from the principal point P of the photograph. If the height of the tower B is 80 m, the height (in meters) of the tower A is _____

Key: (90)

Exp:

For Tower B,

Radial distance of top of tower, $r = 6 \text{ cm}$

Length of image, $d = 2 \text{ cm}$

Height of tower, $h_2 = 80 \text{ m}$

$$\therefore d = \frac{r \cdot h_2}{H - h_1}$$

$$\Rightarrow H - h_1 = \frac{r \cdot h_2}{d} = \frac{6 \times 80}{2} = 240 \text{ m}$$

For Tower A,

$$\therefore d = \frac{r \cdot h_2}{H - h_1}$$

$r = 4 \text{ cm}, d = 1.5 \text{ cm}, H - h_1 = 240 \text{ m}$

$$\Rightarrow h_2 = 90 \text{ m}$$

General Aptitude

Q. No. 1 - 5 Carry One Mark Each

1. There was no doubt that their work was thorough.
Which of the words below is closest in meaning to the underlined word above?
(A) Pretty (B) Complete (C) Sloppy (D) Haphazard

Key: (B)

2. Four cards lie on a table. Each card has a number printed on one side and a colour on the other. The faces visible on the cards are 2, 3, red, and blue.

Proposition: If a card has an even value on one side, then its opposite face is red.

The cards which MUST be turned over to verify the above proposition are

- (A) 2, Red (B) 2, 3, red (C) 2, blue (D) 2, red, blue

Key: (C)

Exp: In order to verify this propositions we have to turn to card 2 and blue from given 4 cards as proposition says it has even an one side opposite is red. Vice-verse might or might not be true so, answer (C) as all other options are eliminated.

3. Two dice are thrown simultaneously. The probability that the product of the numbers appearing on the top faces of the dice is a perfect square is

- (A) 1/9 (B) 2/9 (C) 1/3 (D) 4/9

Key: (B)

Exp: Required probability = $\frac{8}{36} = \frac{2}{9}$

4. What is the value of x when $81 \times \left(\frac{16}{25}\right)^{x+2} \div \left(\frac{3}{5}\right)^{2x+4} = 144$?

- (A) 1 (B) -1 (C) -2 (D) Cannot be determined

Key: (B)

Exp: $\frac{\left(\frac{16}{25}\right)^{x+2}}{\left(\frac{3}{5}\right)^{2x+4}} \times 81 = 144$

$$\Rightarrow \left(\frac{4}{3}\right)^{2x+4} \times 81 = 144 \Rightarrow \left(\frac{4}{3}\right)^{2x} \cdot \frac{4^4}{3^4} \times 81 = 144$$

$$\Rightarrow \left(\frac{4}{3}\right)^{2x} = \frac{9}{16} \Rightarrow x = -1$$

5. The event would have been successful if you _____ able to come.

- (A) are (B) had been (C) have been (D) would have been

Key: (B)

Q. No. 6- 10 Carry Two Marks Each

6. P,Q,R,S,T and U are seated around a circular table. R is seated two places to the right of Q.P is seated three places to the left of R. S is seated opposite U. If P and U now switch seats. Which of the following must necessarily be true?

- (A) P is immediately to the right of R
(B) T is immediately to the left of P

- (C) T is immediately to the left of P or P is immediately to the right of Q
(D) U is immediately to the right of R or P is immediately to the left of T

Key: (C)

Exp:

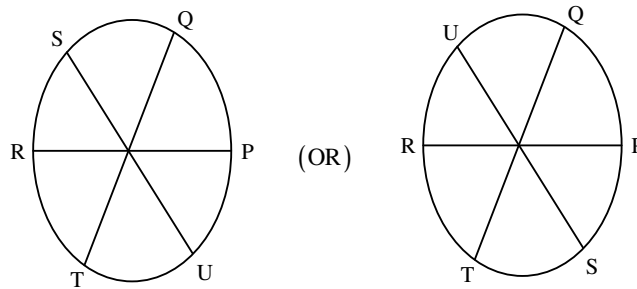

$P \leftrightarrow U$ Now, P & U switch seats; then there are 2 possibilities

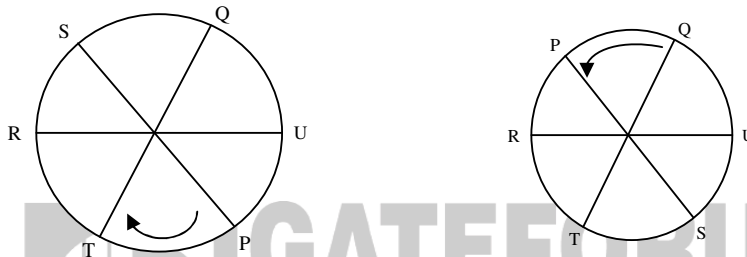

7. Bhaichung was observing the pattern of people entering and leaving a car service centre. There was a single window where customers were being served. He saw that people inevitably came out of the centre in the order that they went in. However, the time they spent inside seemed to vary a lot: some people came out in a matter of minutes while for others it took much longer.

From this, what can one conclude?

- (A) The centre operates on a first-come-first-served basis but with variable service times, depending on specific customer needs.
(B) Customers were served in an arbitrary order since they took varying amounts of time for service completion in the centre.
(C) Since some people came out within a few minutes of entering the centre. The system is likely to operate on a last-come-first-served basis.
(D) Entering the centre early ensured that one would have shorter service times and most people attempted to do this.

Key: (A)

Exp: People coming out in the same order in which they enter indicates that the centre operates on a first come first serve basis.

8. A map shows the elevations of Darjeeling, Gangtok, Kalimpong, Pelling, and Siliguri. Kalimpong is at a lower elevation than Gangtok. Pelling is at a lower elevation than Gangtok. Pelling is at a higher elevation than Siliguri. Darjeeling is at a higher elevation than Gangtok. Which of the following statements can be inferred from the paragraph above?
- Pelling is at a higher elevation than Kalimpong
 - Kalimpong is at a lower elevation than Darjeeling

- iii. Kalimpong is at a higher elevation than siliguri
 - iv. Siliguri is at a lower elevation than Gangtok
- (A) Only ii (B) Only ii and iii (C) Only ii and iv (D) Only iii and iv

Key: (C)

9. Budhan covers a distance of 19 km in 2 hours by cycling one fourth of the time and walking the rest. The next day he cycles (at the same speed as before) for half the time and walks the rest (at the same speed as before) and covers 26 km in 2 hours. The speed in km/h at which Budhan walks is
- (A) 1 (B) 4 (C) 5 (D) 6

Key: (D)

Exp: Let cycling speed=C; and walking speed=W

$$C\left(\frac{1}{2}\right) + W\left(\frac{3}{2}\right) = 19 \dots\dots(1)$$

$$C + W = 26 \dots\dots(2)$$

On solving (1) & (2), we get W=6 km/hr

10. The points in the graph below represent the halts of a lift for duration of 1 minute, over a period of 1 hour.

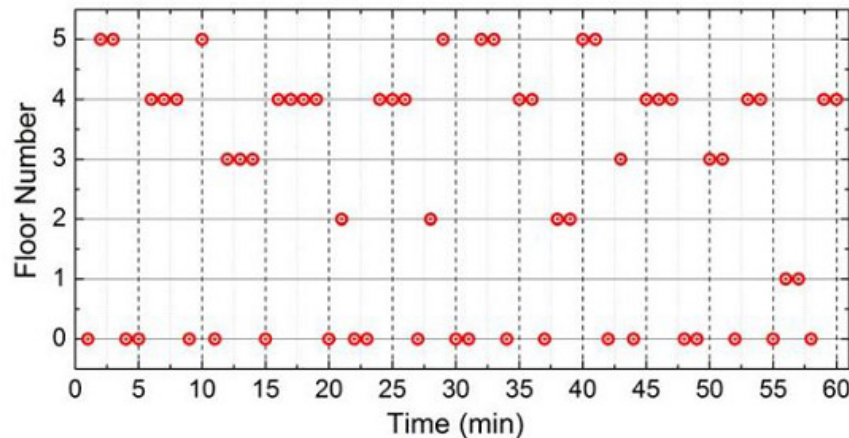

Which of the following statements are correct?

- i. The elevator never moves directly from any non-ground floor to another non-ground floor over the one hour period
 - ii. The elevator stays on the fourth floor for the longest duration over the one hour period
- (A) Only i (B) Only ii (C) Both i and ii (D) Neither i nor ii

Key: (D)

Exp: (i). is incorrect as its has more directly.

(ii). is incorrect as it stayed for maximum duration on ground floor.